

ECO#	REV:	DESCRIPTION	REV. BY:	APP. BY:	DATE
1988	C	Connect DGND plane to chassis GND thru standoff	WGW		11-9-98

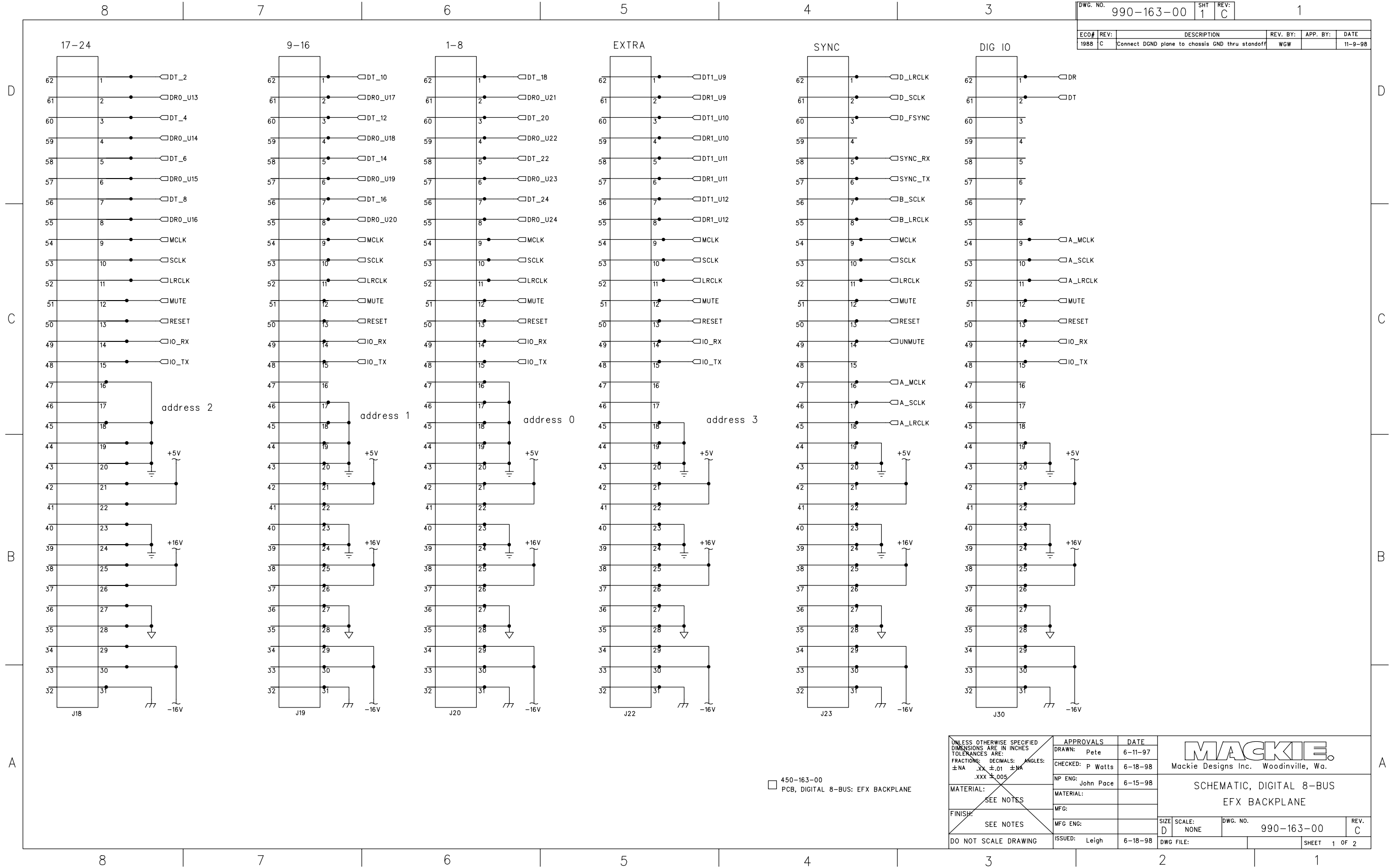

□ 450-163-00
PCB, DIGITAL 8-BUS: EFX BACKPLANE

UNLESS OTHERWISE SPECIFIED DIMENSIONS ARE IN INCHES TOLERANCES ARE:		APPROVALS		DATE
FRACTIONS:	DECIMALS:	DRAWN: Pete		6-11-97
±NA .XX ±.01 ±NA .XXX ±.005	ANGLES:	CHECKED: P Watts		6-18-98
MATERIAL: SEE NOTES		NP ENG: John Pace		6-15-98
FINISH: SEE NOTES		MFG:		
DO NOT SCALE DRAWING		MFG ENG:		
		ISSUED: Leigh		6-18-98

MACKIE
Mackie Designs Inc. Woodinville, Wa.

SCHEMATIC, DIGITAL 8-BUS
EFX BACKPLANE

SIZE: D	SCALE: NONE	DWG. NO. 990-163-00	REV. C
DWG FILE:		SHEET 1 OF 2	

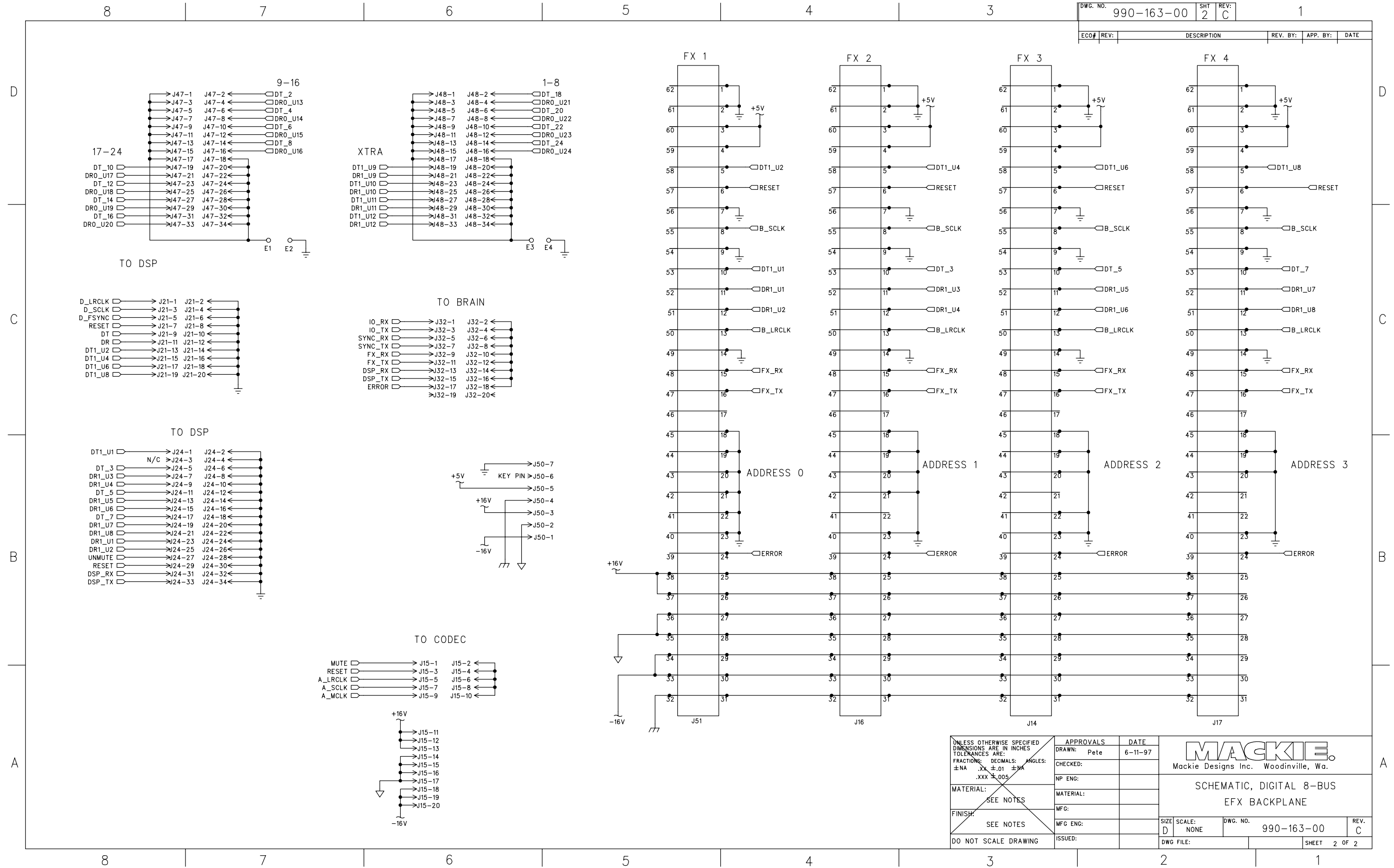

UNLESS OTHERWISE SPECIFIED DIMENSIONS ARE IN INCHES TOLERANCES ARE: FRACTIONS: DECIMALS: ANGLES: ±NA .XX ±.01 ±MA .XXX ±.005	APPROVALS	DATE	MACKIE. Mackie Designs Inc. Woodinville, Wa.
	DRAWN: Pete	6-11-97	
	CHECKED:		
	NP ENG:		
MATERIAL:	MATERIAL:		SCHEMATIC, DIGITAL 8-BUS EFX BACKPLANE
SEE NOTES	MFG:		
FINISH:	MFG ENG:		SIZE: D
DO NOT SCALE DRAWING	ISSUED:		SCALE: NONE
			DWG. NO. 990-163-00
			REV. C
			SHEET 2 OF 2

MACKIE DESIGNS.™

© 1998

055-163-00 REV: ---

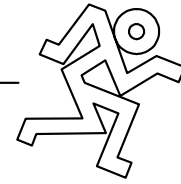

DIGITAL 8-BUS: EFX BACKPLANE

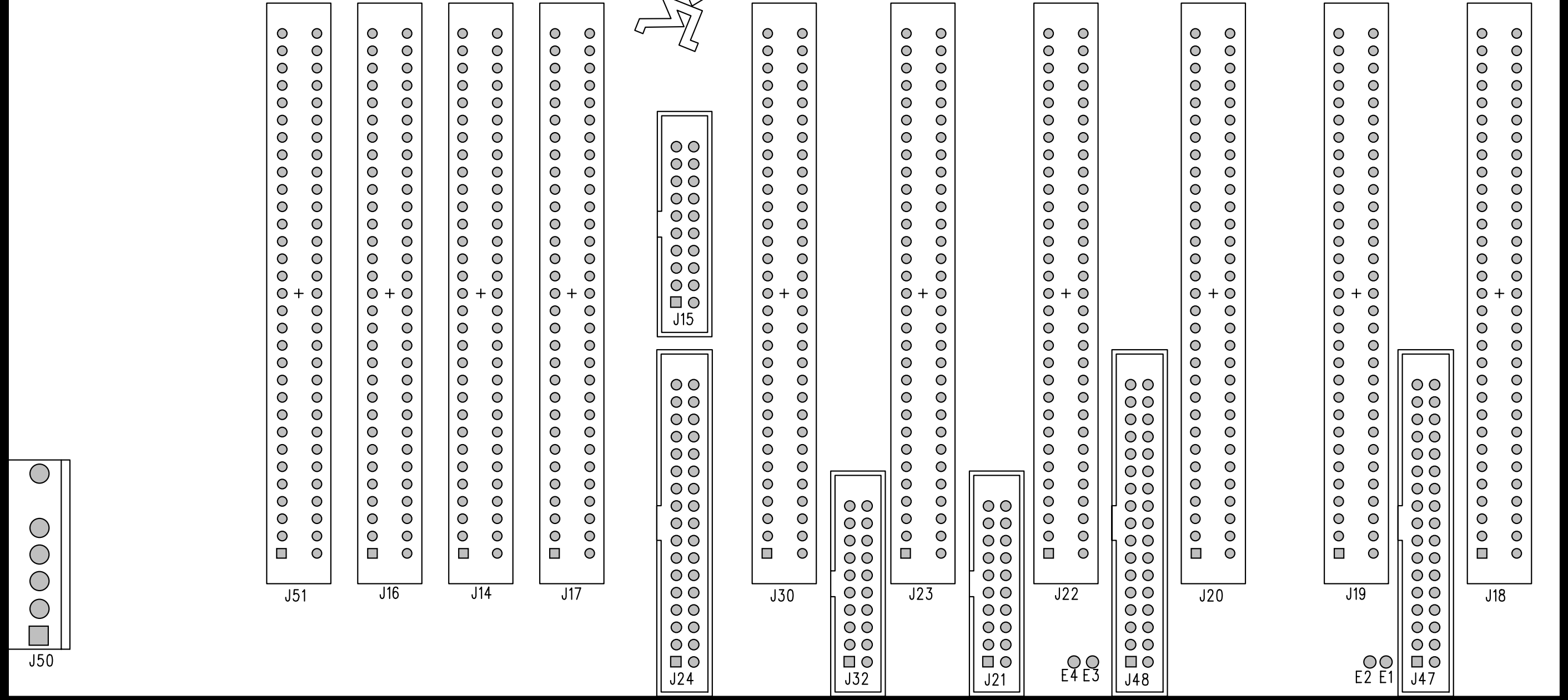

BOTTOM

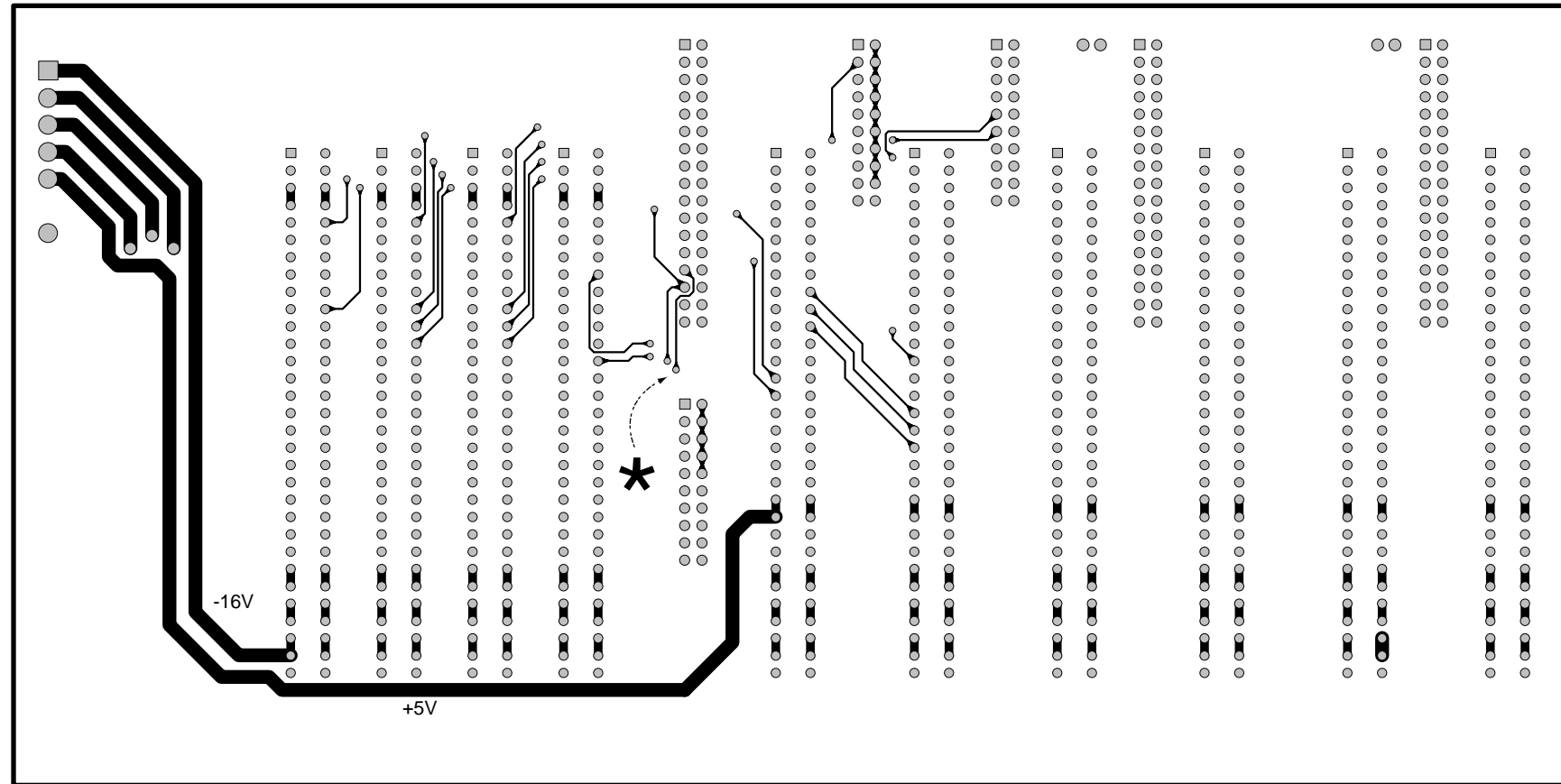

TOP

DIGITAL 8-BUS: EFX BACKPLANE

