

ECO#	REV:	DESCRIPTION	REV. BY:	DATE
6739	A00	RELEASE TO PRODUCTION	KR	2-5-04
6996	A01	REVISED GAIN POT	SDPL	4-27-04

D

D

C

C

B

B

A

A

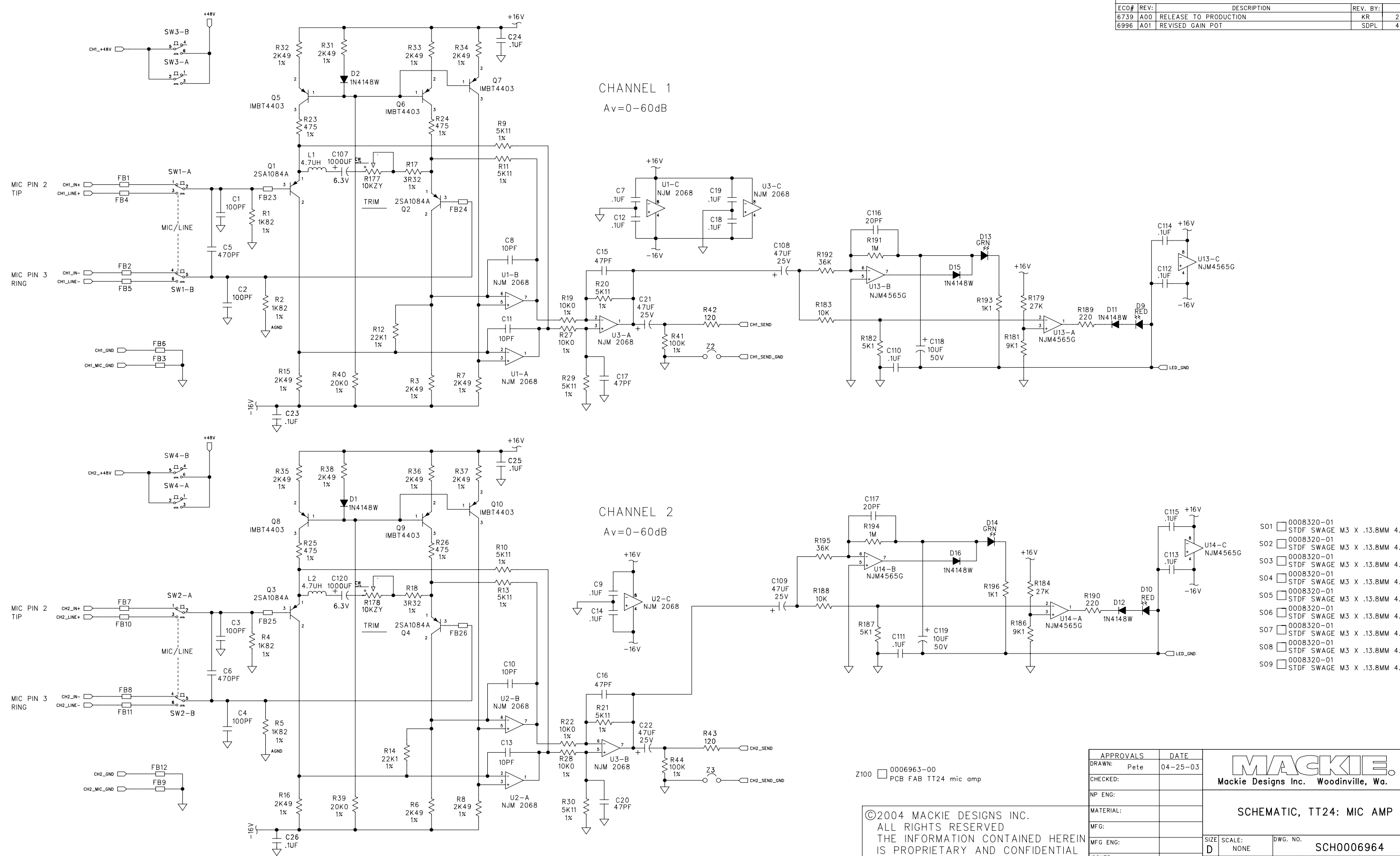

- S01 0008320-01 STDF SWAGE M3 X .13.8MM 4.7 DIA
- S02 0008320-01 STDF SWAGE M3 X .13.8MM 4.7 DIA
- S03 0008320-01 STDF SWAGE M3 X .13.8MM 4.7 DIA
- S04 0008320-01 STDF SWAGE M3 X .13.8MM 4.7 DIA
- S05 0008320-01 STDF SWAGE M3 X .13.8MM 4.7 DIA
- S06 0008320-01 STDF SWAGE M3 X .13.8MM 4.7 DIA
- S07 0008320-01 STDF SWAGE M3 X .13.8MM 4.7 DIA
- S08 0008320-01 STDF SWAGE M3 X .13.8MM 4.7 DIA
- S09 0008320-01 STDF SWAGE M3 X .13.8MM 4.7 DIA

Z100 0006963-00 PCB FAB TT24 mic amp

©2004 MACKIE DESIGNS INC.
 ALL RIGHTS RESERVED
 THE INFORMATION CONTAINED HEREIN
 IS PROPRIETARY AND CONFIDENTIAL
 PROPERTY OF MACKIE DESIGNS INC.

APPROVALS	DATE
DRAWN: Pete	04-25-03
CHECKED:	
NP ENG:	
MATERIAL:	
MFG:	
MFG ENG:	
ISSUED:	

MACKIE
 Mackie Designs Inc. Woodinville, Wa.

SCHEMATIC, TT24: MIC AMP

SIZE: D	SCALE: NONE	DWG. NO. SCH0006964	REV. A01
DWG FILE:		SHEET 1 OF 5	



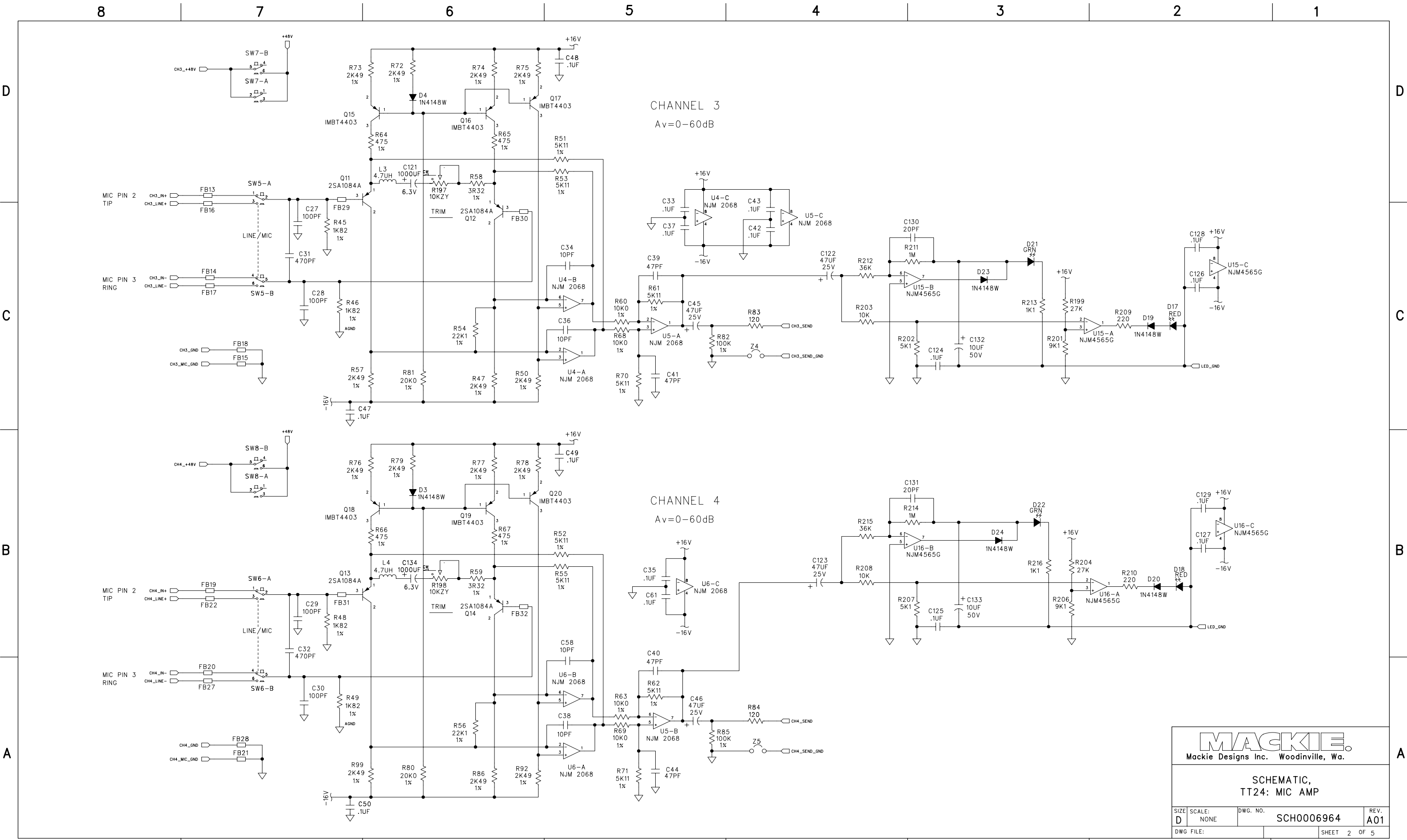

MACKIE
Mackie Designs Inc. Woodinville, Wa.

SCHEMATIC, TT24: MIC AMP			
SIZE D	SCALE NONE	DWG. NO. SCH0006964	REV. A01
DWG FILE:		SHEET 2 OF 5	

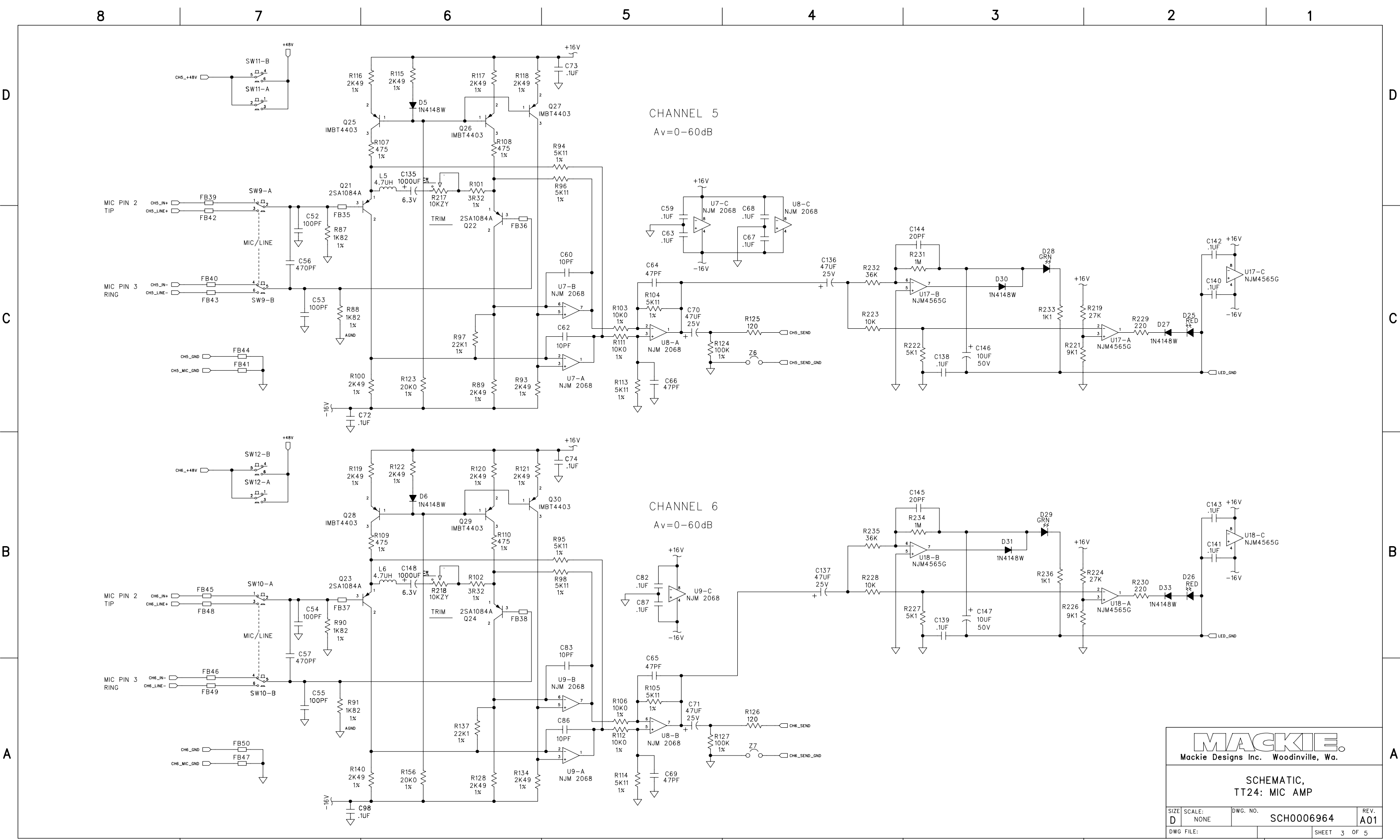

CHANNEL 5
Av=0-60dB

CHANNEL 6
Av=0-60dB

MACKIE
Mackie Designs Inc. Woodinville, Wa.

SCHMATIC,
TT24: MIC AMP

SIZE: D	SCALE: NONE	DWG. NO.: SCH0006964	REV.: A01
DWG FILE:		SHEET 3 OF 5	

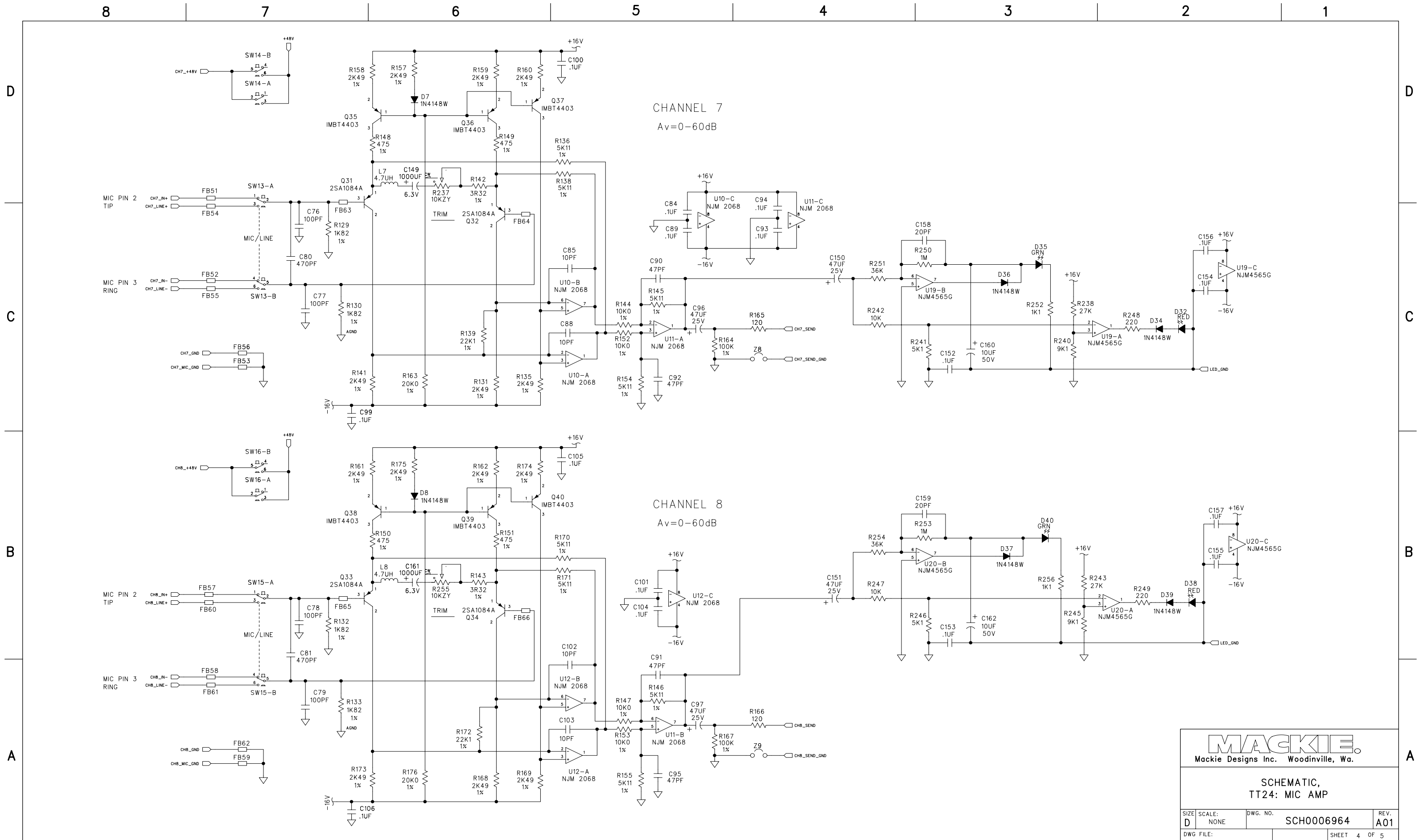

CHANNEL 7
Av=0-60dB

CHANNEL 8
Av=0-60dB

MACKIE
Mackie Designs Inc. Woodinville, Wa.

SCHMATIC,
TT24: MIC AMP

SIZE: D	SCALE: NONE	DWG. NO.: SCH0006964	REV.: A01
DWG FILE:		SHEET 4 OF 5	

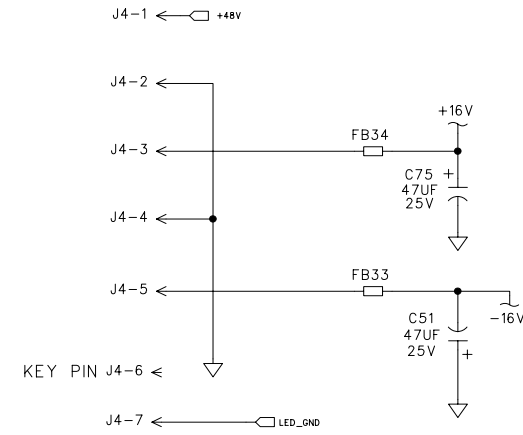
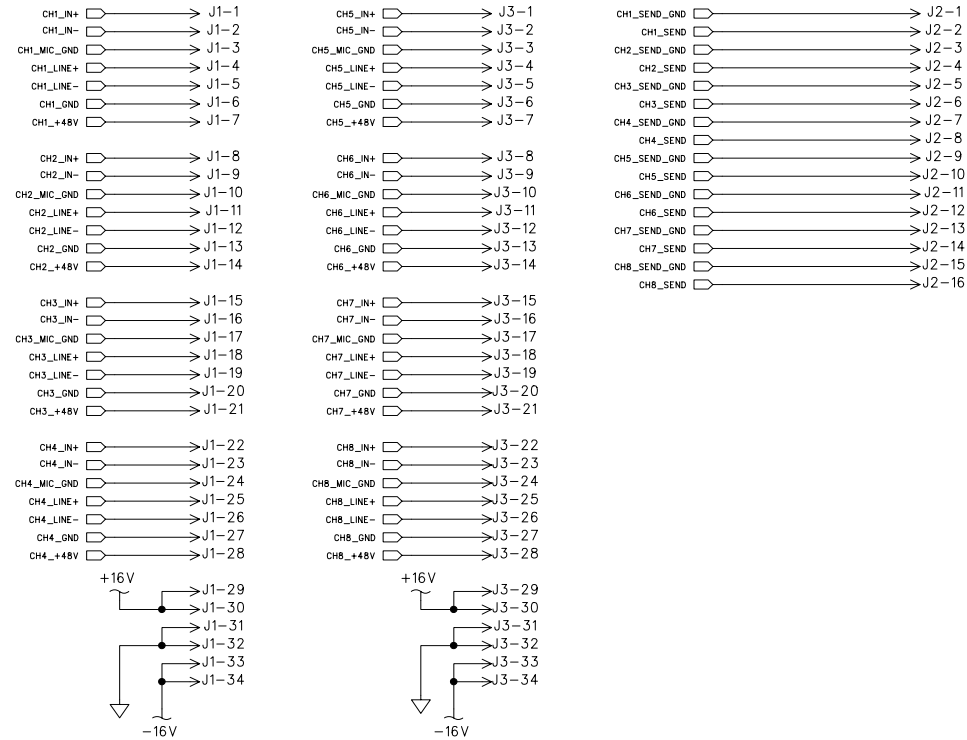

MACKIE.
Mackie Designs Inc. Woodinville, Wa.

SCHMATIC,
TT24: MIC AMP

SIZE D	SCALE: NONE	DWG. NO. SCH0006964	REV. A01
DWG FILE:		SHEET 5 OF 5	