

ECO#	REV:	DESCRIPTION	REV. BY:	APP. BY:	DATE
2716	B	LOCAL FIDUCIALS ADDED TO U3, U7, U14. TOOLING HOLE LOCATIONS PLACED BACK ON BOARD FOR TEST FIXTURE.	JJI		

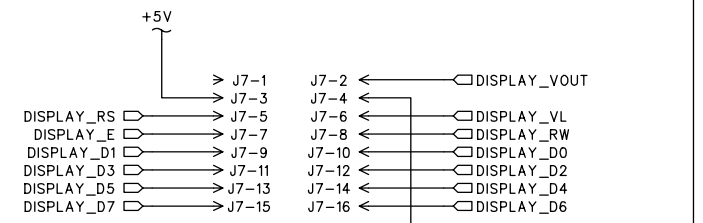

APPROVALS	DATE
DRAWN: JJJ	4-17-00
CHECKED:	
NP ENG:	
MATERIAL:	
MFG:	
MFG ENG:	
ISSUED:	

<b>MACKIE.</b>	
Mackie Designs Inc. Woodville, Wa.	
SCHEMATIC, HDR24/96: BRAIN	
SIZE: D	SCALE: NONE
DWG. NO. 990-180-00	REV. B
DWG. FILE:	SHEET 1 OF 2

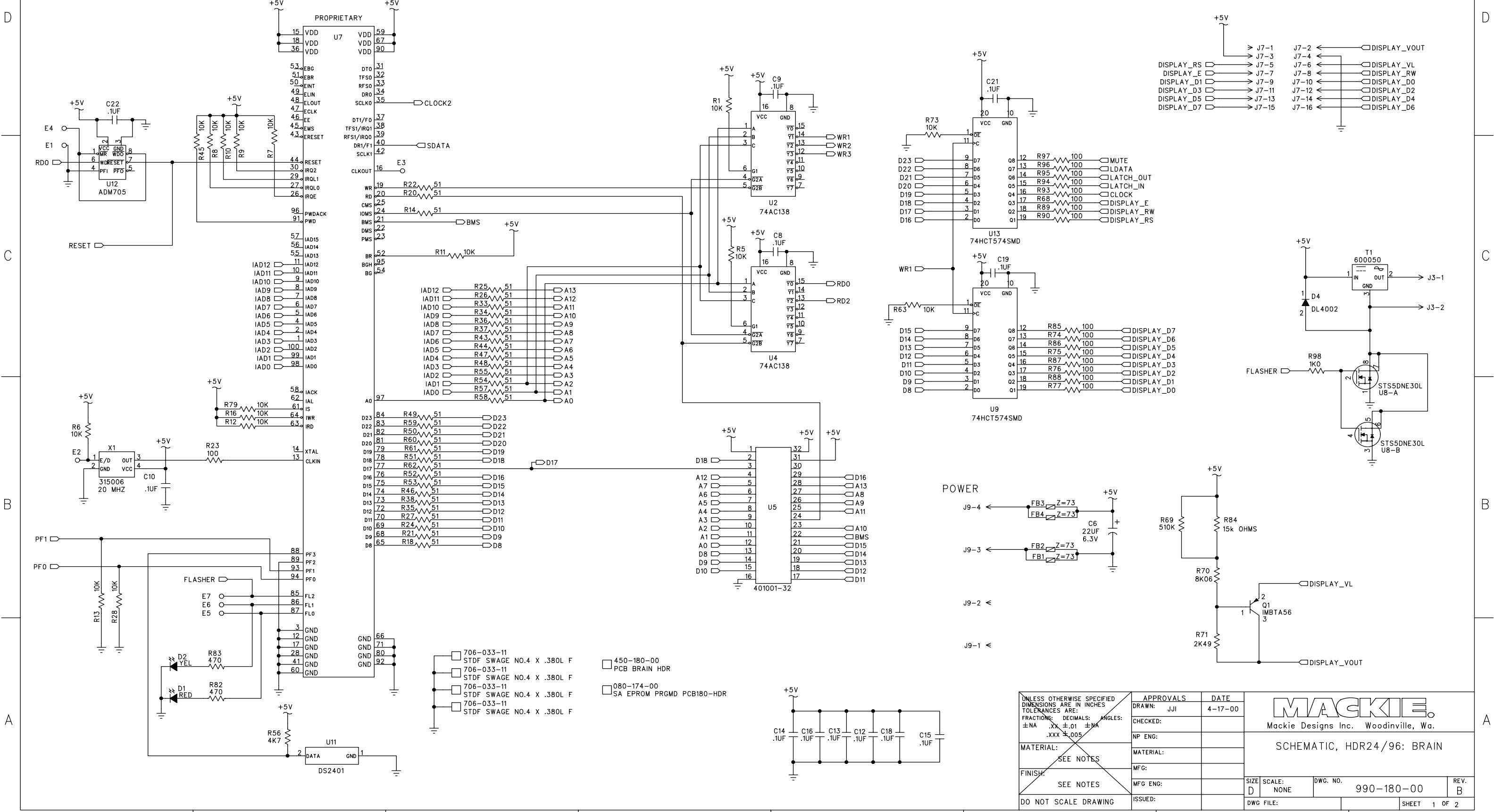
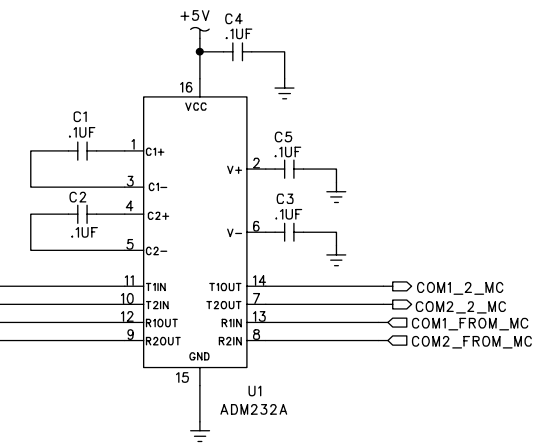
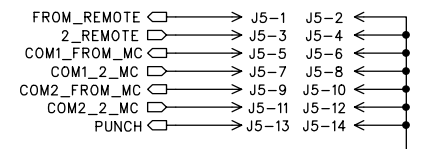
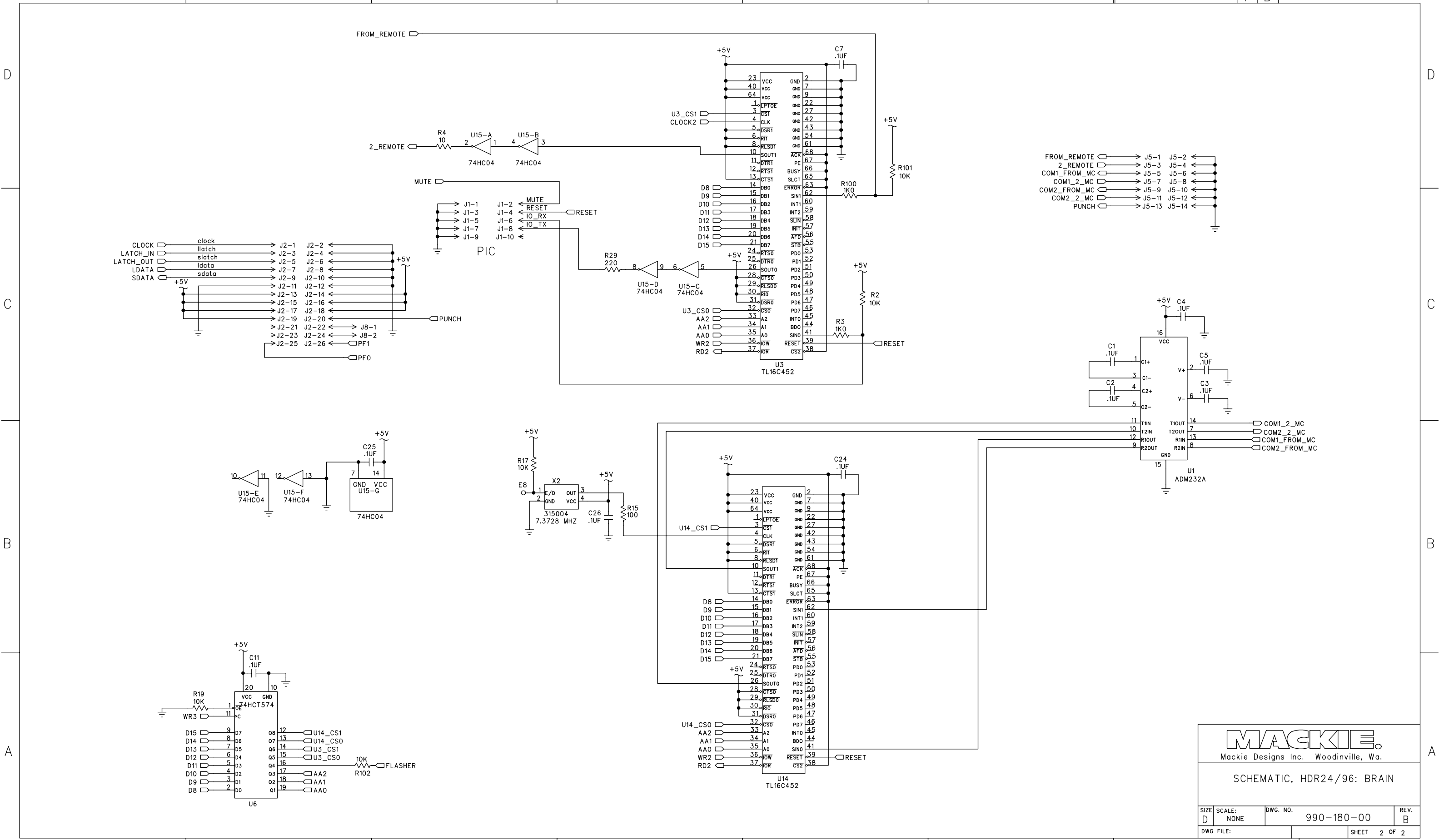

**MACKIE.**  
 Mackie Designs Inc. Woodville, Wa.

SCHMATIC, HDR24/96: BRAIN

SIZE: D	SCALE: NONE	DWG. NO. 990-180-00	REV. B
DWG FILE:		SHEET 2 OF 2	

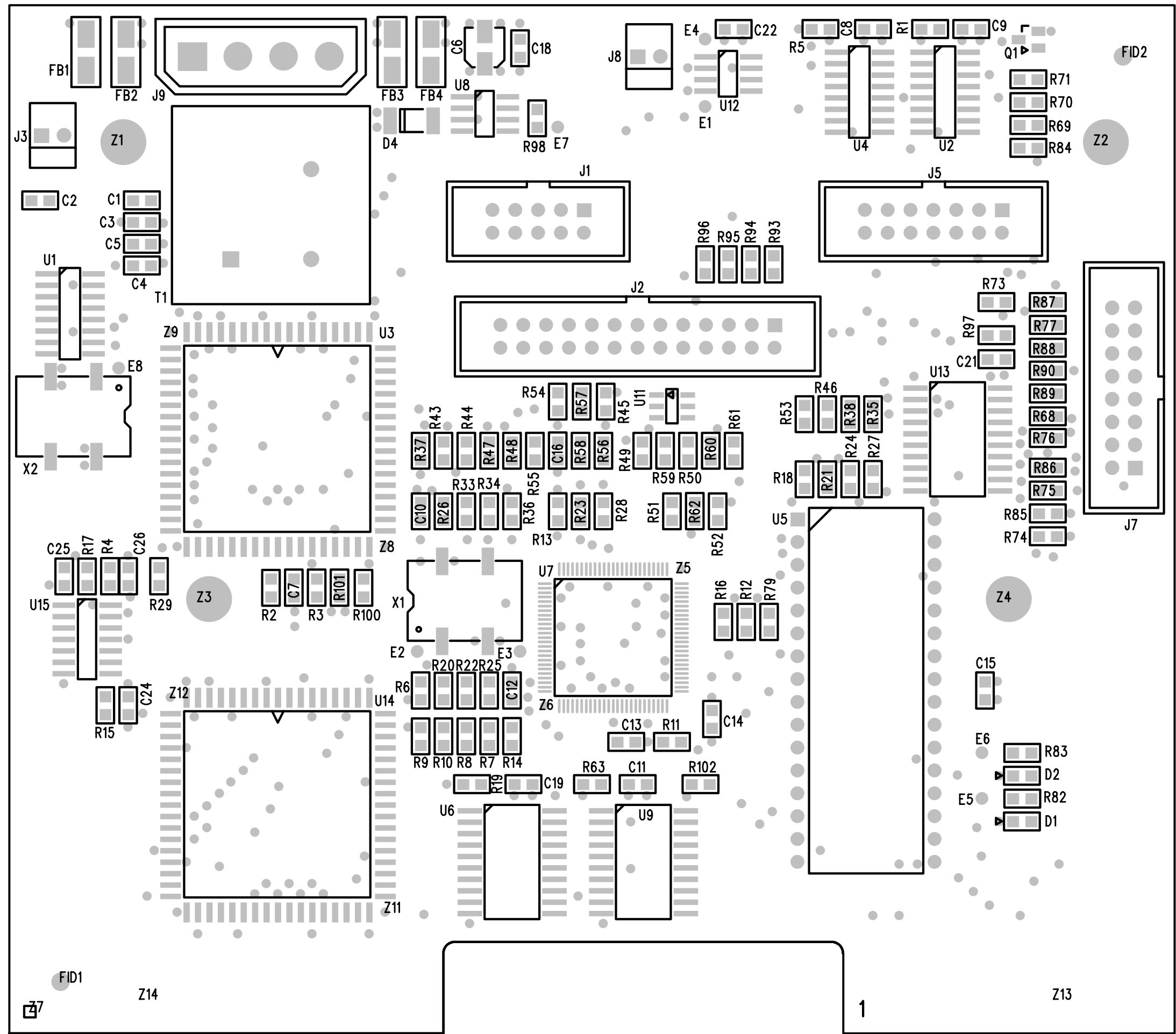

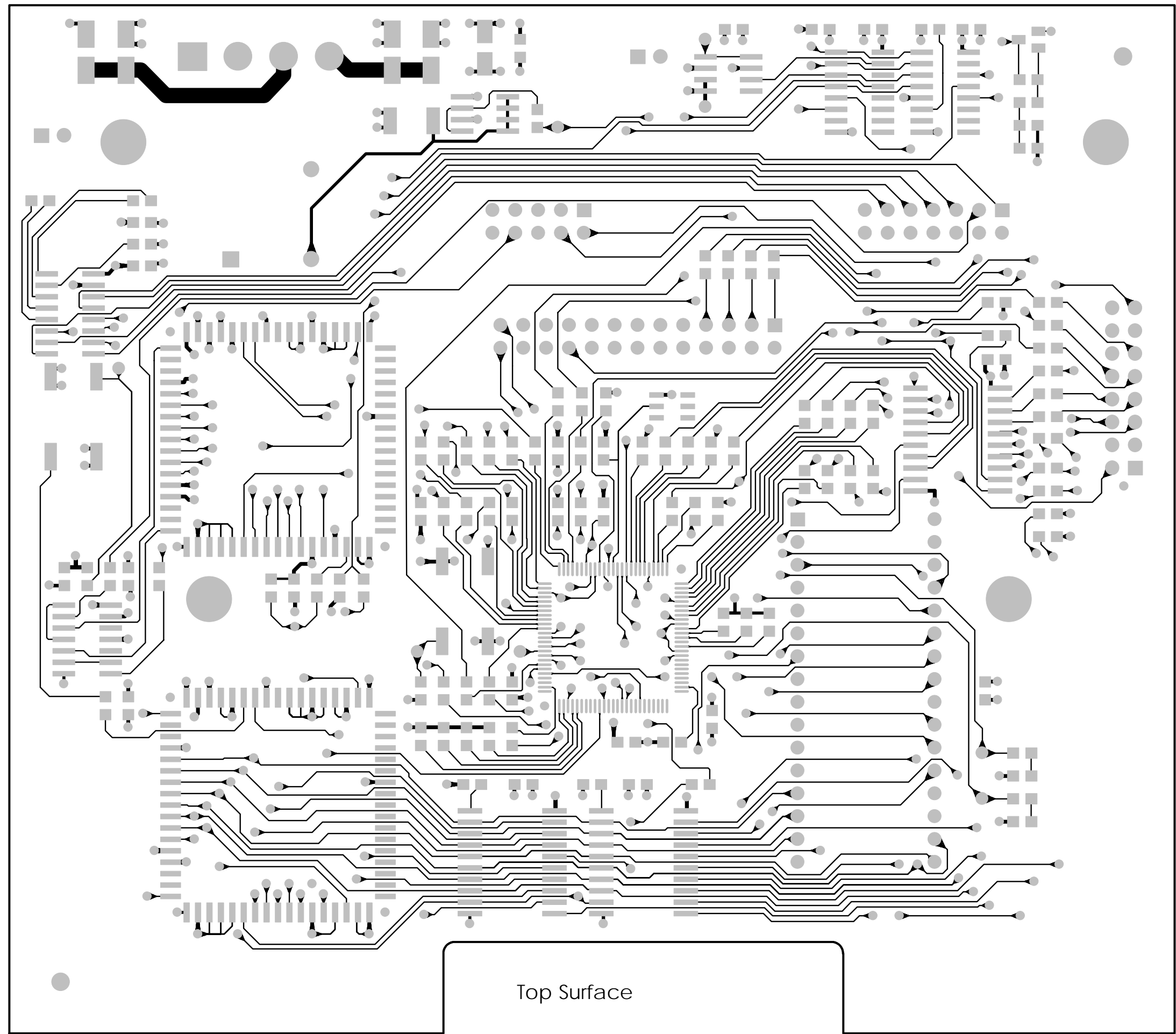

Top Surface

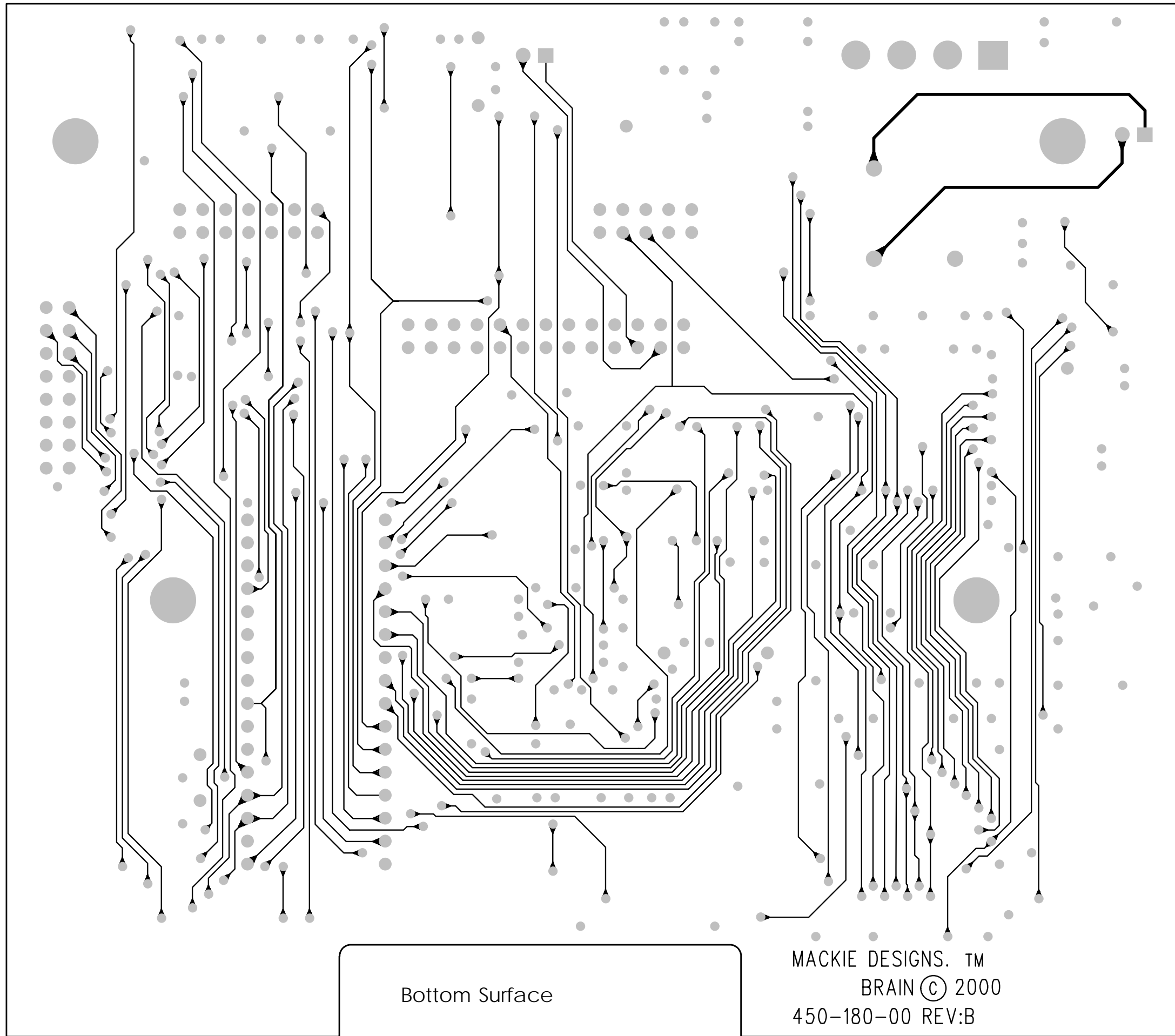

Bottom Surface

MACKIE DESIGNS.™  
BRAIN © 2000  
450-180-00 REV:B